

LED STREET LIGHTS

INSTALLATION INSTRUCTIONS

IMPORTANT SAFEGUARDS

When using electrical equipment, basic safety precautions should always be followed including the following:

READ AND FOLLOW ALL SAFETY INSTRUCTIONS

1. To avoid the possibility of electrical shock, turn off power supply before installation or servicing. Installation and servicing should be performed by qualified personnel.
2. When closing cover of fixture, be sure all wires are inside housing to avoid pinching wires.
3. If Photo Receptacle is installed refer to "Photo Control" section for instructions.
4. Product must be installed in accordance with your local electrical code. If you are not familiar with these codes and requirements, consult a qualified electrician.
5. Do not change the structure or any components of the fixture to ensure safety.

SAVE THIS INSTRUCTIONS FOR FUTURE REFERENCE

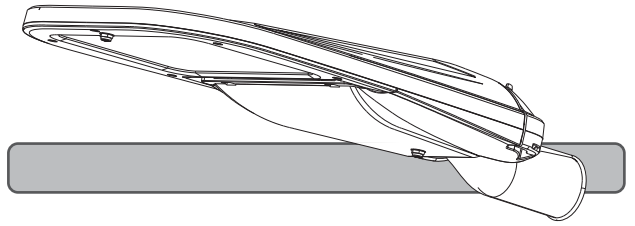

100-240V/277V AC, 50/60Hz, Suitable for Wet Locations (IP66), Class I
 *Max installation height: 15M
 *Pole fitter diameter: Φ 60mm (2.4") / *48mm diameter need longer screws
 *This product must be grounding

Power	Dimension	EPA	Weight
25W	614 x224 x135 mm	0.165 m ²	5.8 kg
35W			5.9 kg
55W			6.0 kg
60W	726 x357 x127 mm	0.311 m ²	7.8 kg
90W			8.1 kg
120W			8.2 kg
120W			12.0 kg
150W	861 x447 x153 mm	0.462 m ²	12.0 kg
180W			12.1 kg
200W			12.2 kg

TO INSTALL:

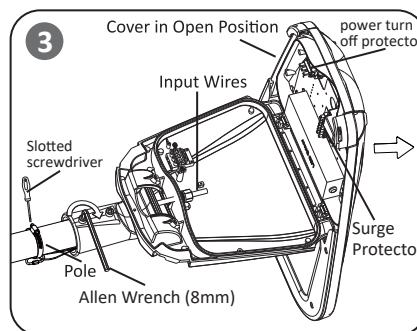
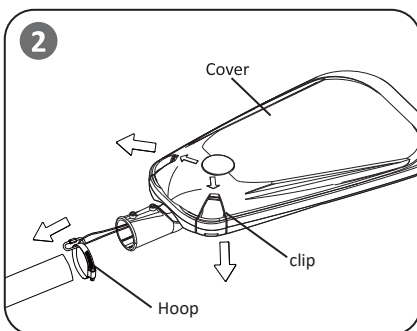
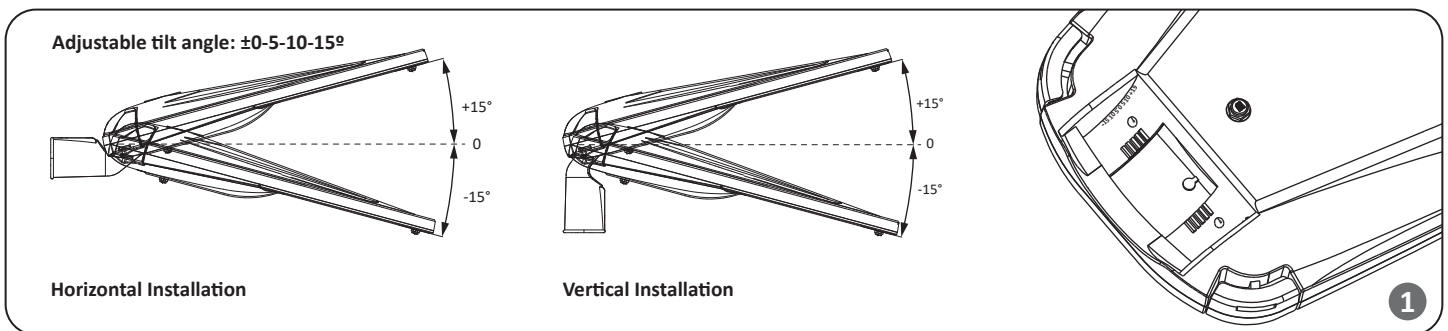

Recommended torque: 17Nm \pm 1Nm.

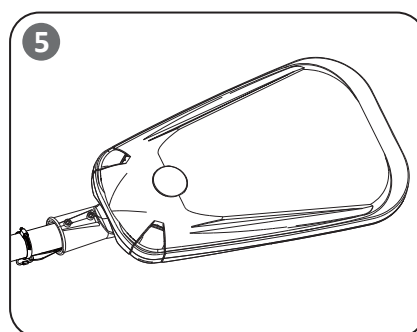
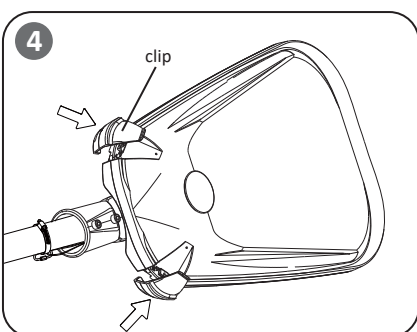

STANDARD MOUNTING

STEP 1:

Adjust the multi-angle fitter (0, 5, 10, 15 degree vertical and 0, 5, 10, 15 degree horizontal) to proper position by 4mm (5/32") allen wrench. See ①.

STEP 2:

Open the left and right clips on the back of the luminaire. See ②.

STEP 3:

Insert the pole and external power cord into the luminaire cavity and hoop of Anti-falling rope. Thread the power cord through the M16 wiring harness retainer. Reserve the related length of wire for connection. Keep the base in horizontal level. Fix the luminaire and pole by allen wrench. Tighten the hoop on the pole by Slotted screwdriver See ③.

STEP 4:

Connect the external power cord to the power turn off protector plug and complete the electrical connections.

STEP 5:

Close the cover and clips. See ④ ⑤.

IMPORTANT

Check whether it concerns an AC(Alternating Current) based or DC(Direct Current) based system.

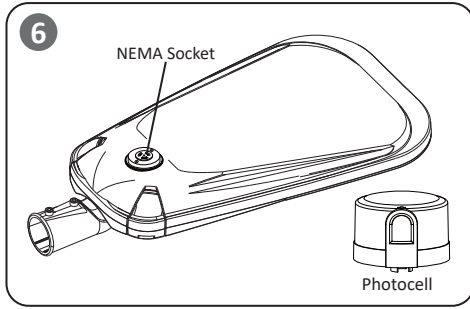

PHOTOCELL (OPTIONAL)

If the fixture with PHOTOCELL function, the NEMA Socket will be installed on the cover of fixture. See 6. Fit the pins of Photocell to NEMA Socket, firmly insert and rotate Photocell to proper position.

<Verifying>

Make sure all the connections done and photocell is well installed on the fixture, switch on the power supply and cover the window of photocell, wait 5 seconds, the fixture will be turned on.

ELECTRICAL CONNECTIONS - 100-240V/277V AC, 50/60Hz

Class I BASED

STEP 1:

Make the following Electrical Connections:

- Connect **INPUT GROUND** conductor to “⊕” position of the surge protector or the female power turn off protector plug.
- Connect **INPUT VOLTAGE** conductor to “L” position of the surge protector or the female power turn off protector plug.
- Connect **INPUT NEUTRAL** conductor to “N” position of the surge protector or the female power turn off protector plug.

STEP 2:

Make sure all excess input wires are pushed into pole, screws are tightened.

STEP 3:

Close cover by firmly pushing cover towards fixture, making sure that no wires are pinched and Sealing gasket are fully engaged.

STEP 4:

If the fixture without a surge protector, please insulate all electrical connections with wire nuts suitable for at least 90°C

Input cable should be at least H05RN-F 3x1.0mm²(SJTW 18AWG) or outdoor grade cable with rubber sheathed(not supplied). The cable must have a minimum cross sectional area of 1.0mm²(18AWG).

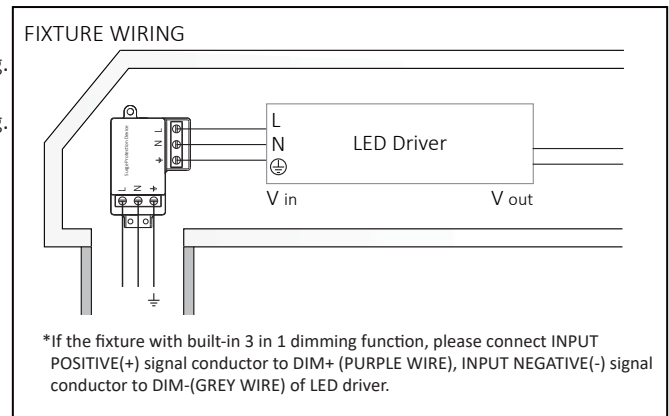

ELECTRICAL CONNECTIONS - 100-240V/277V AC, 50/60Hz

Class II BASED

STEP 1:

Make the following Electrical Connections:

- Connect **INPUT POSITIVE(+)** conductor to “L” position of the surge protector or the female power turn off protector plug.
- Connect **INPUT NEGATIVE(-)** conductor to “N” position of the surge protector or the female power turn off protector plug.

STEP 2:

Make sure all excess input wires are pushed into pole, screws are tightened.

STEP 3:

Close cover by firmly pushing cover towards fixture, making sure that no wires are pinched and Sealing gasket are fully engaged.

STEP 4:

If the fixture without a surge protector, please insulate all electrical connections with wire nuts suitable for at least 90°C

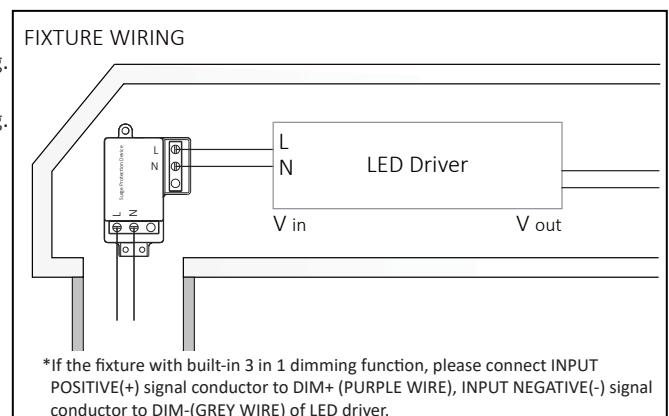

This marking indicates that this product should not be disposed with other household wastes throughout the EU. To prevent possible harm to the environment or human health from uncontrolled waste disposal, recycle it responsibly to promote the sustainable reuse of material resources. To return your used device, please use the return and collection systems or contact the retailer where the product was purchased. They can take this product for environmental safe recycling.